

Ⓓ Keg Top Dome Lettering  
Stamp Government Warning: YES

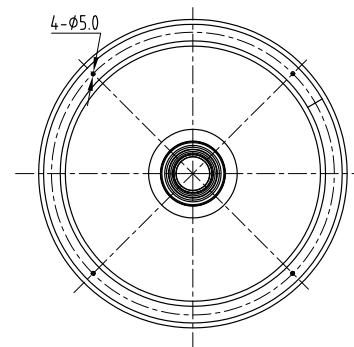

Ⓕ Keg Bottom Burst Disc: NO

### Technical Requirements

No.	Item	Technical Data			Confirm	
1	Material	Top Chimb	AISI SS304	2.0±0.1mm	950-1050N/mm <sup>2</sup>	
		Bottom Chimb	AISI SS304	2.0±0.1mm	650-750N/mm <sup>2</sup>	
		Body	AISI SS304	1.5±0.1mm	580-700N/mm <sup>2</sup>	
2	Marking	LOGO	NO			
		Essential information of the keg	YES	Stamp	The details please see dimension Ⓒ	
		Container Number	NO			
3	Top Dome Lettering	Top Dome Government Warning	YES	Stamp	The details please see dimension Ⓓ	
4	Colour Band	Colour Band	NO			
5	Safety Device	Burst Disc	NO		The details please see dimension Ⓕ	
6	Neck	Material	AISI SS304	Type	RS-D-USA	
		Brand	Aobaosi			
		Type	RS-D Type With Double Circlip			
8	Internal and external finish	Pickled and Passivated				

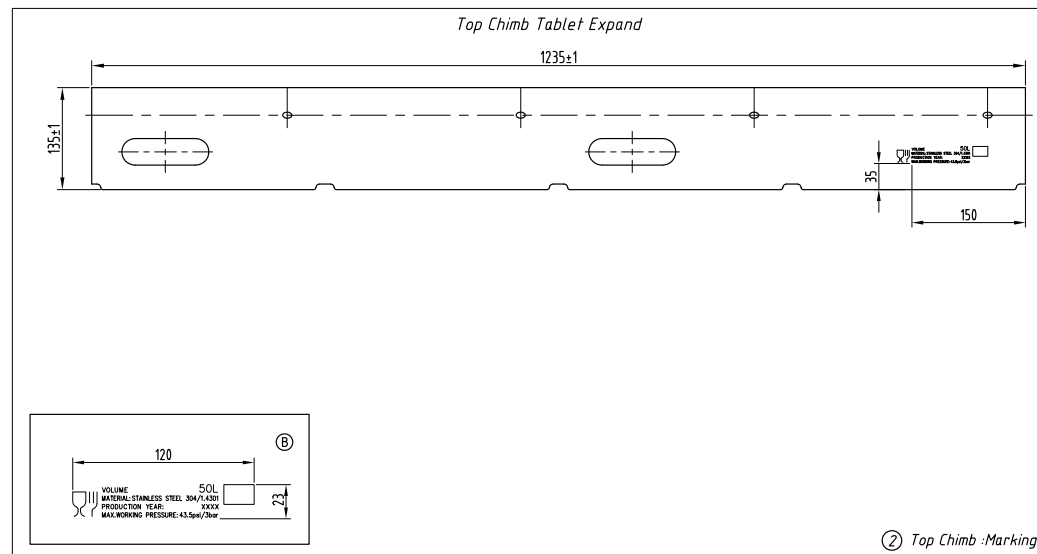

Ⓒ Top Chimb :Marking

#### Notes:

- Capacity: 50.2L±0.2L
- Weight: 11.8kg±5% (Excluding the spear)
- Working pressure: 3.0bar, testing pressure: 6.3bar;
- Remove all burrs, sharp edges and swarf.

Drawing Approval:

Signature: \_\_\_\_\_

Date: \_\_\_\_\_

				<b>Lawson Kegs Inc.</b> Add: 55 Industrial Road, Unit 11 & 12 Tottenham, Ontario L0G 1W0, Canada Tel: (800) 519-5534 Email: info@lawsonkegs.com		<b>Lawson Kegs Inc.</b> www.lawsonkegs.com	
ITEM	AMENDMENTS	SIGNATURE	DATE	Material: Stainless Steel		Total: 1 Pages	Page 1
Design By	Checked By	Approved By	Projection:	Unit: mm		Weight: 11.8kg	
John Chen			Title: Keg Euro 50L Barrel (Stackable)	Ref: MJ.ST.E50.LK.00.02		Scale: 1:10	
11/24/2017						Rev: A	